

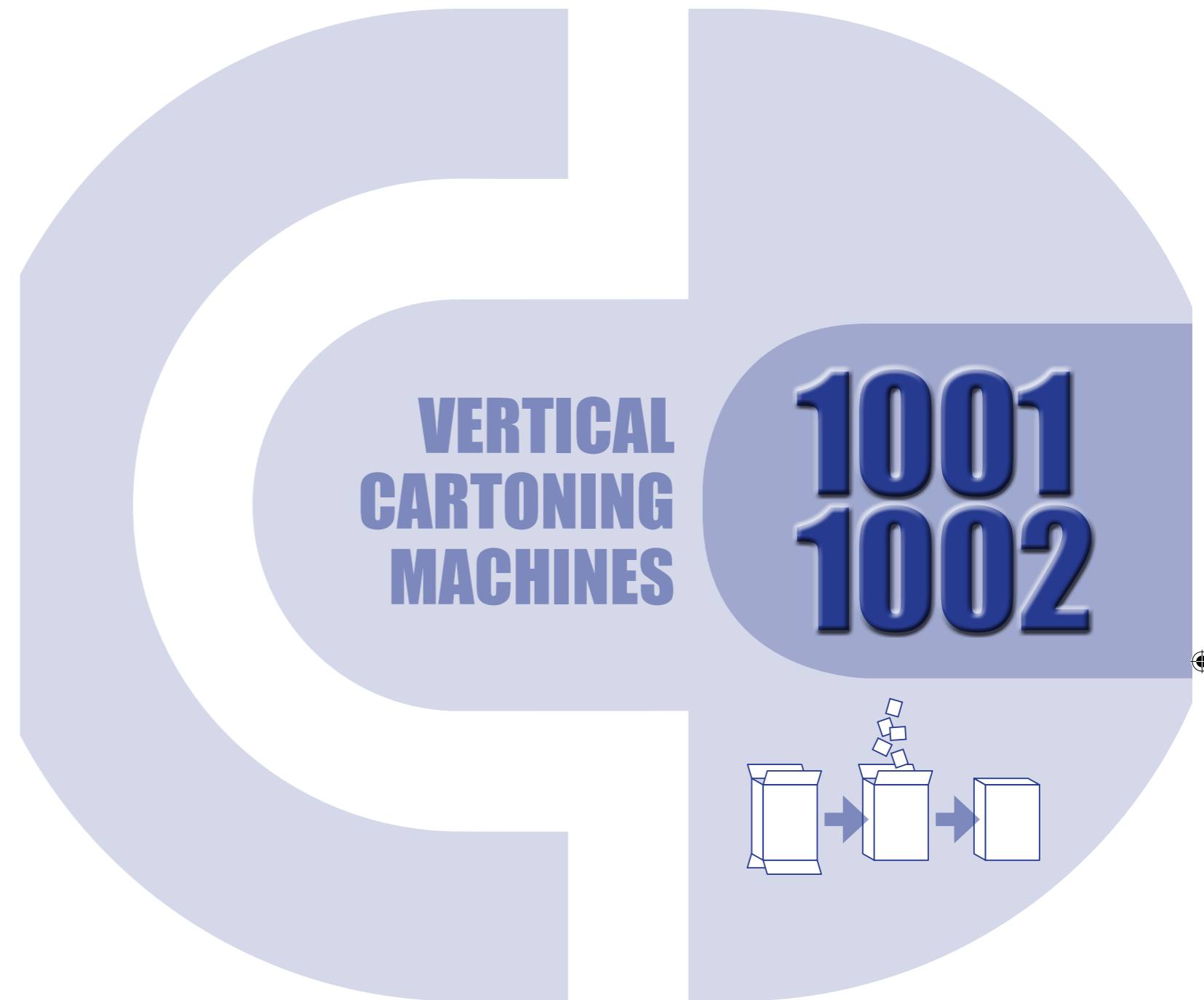

## VERTICAL CARTONING MACHINES



**CURTI Costruzioni Meccaniche S.p.A.**  
Via Emilia Ponente, 750 - 48014 Castel Bolognese (Ra) - ITALY  
Tel. +39 0546 655911 - Fax +39 0546 655904  
E-mail: info@curti.com - Web: www.curti.com



# 1001

**Processable products:** short pasta, rice, sweets, candies, chewing-gums, twist wrapped chocolates, chocolate powder and flakes, cereals, dried fruit, dried vegetables, petfood, seeds, etc...

## STANDARD VERSION

- Main structure in steel and aluminum
- Rotary carton feeding by two arms
- Product feeding by volumetric doser, auger filler, multi-head weigher, counting unit
- Four dosing cups
- Flip-top, tuck-in, hot melt glue, even flaps, labyrinth carton closure

## HIGH SPEED VERSION

- Ideal for candies, chocolates, chewing-gums, sweets and any other bulk products
- Carton feeding by rotary arms
- Product feeding by volumetric doser, counting unit, multi-head weigher
- Flip-top, tuck-in, hot melt glue, even flaps, labyrinth carton closure

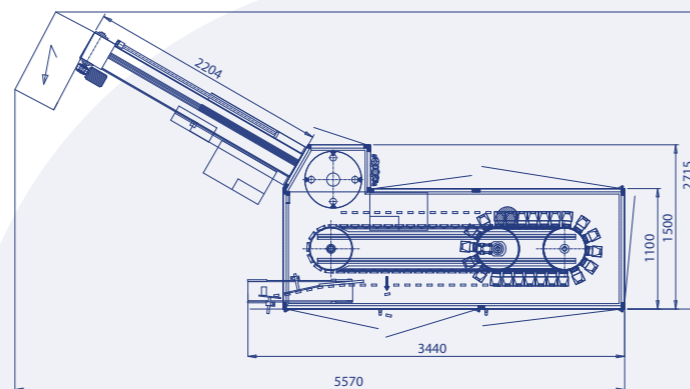

**Overall dimensions (mm):**  
5570 x 2715 x H1880

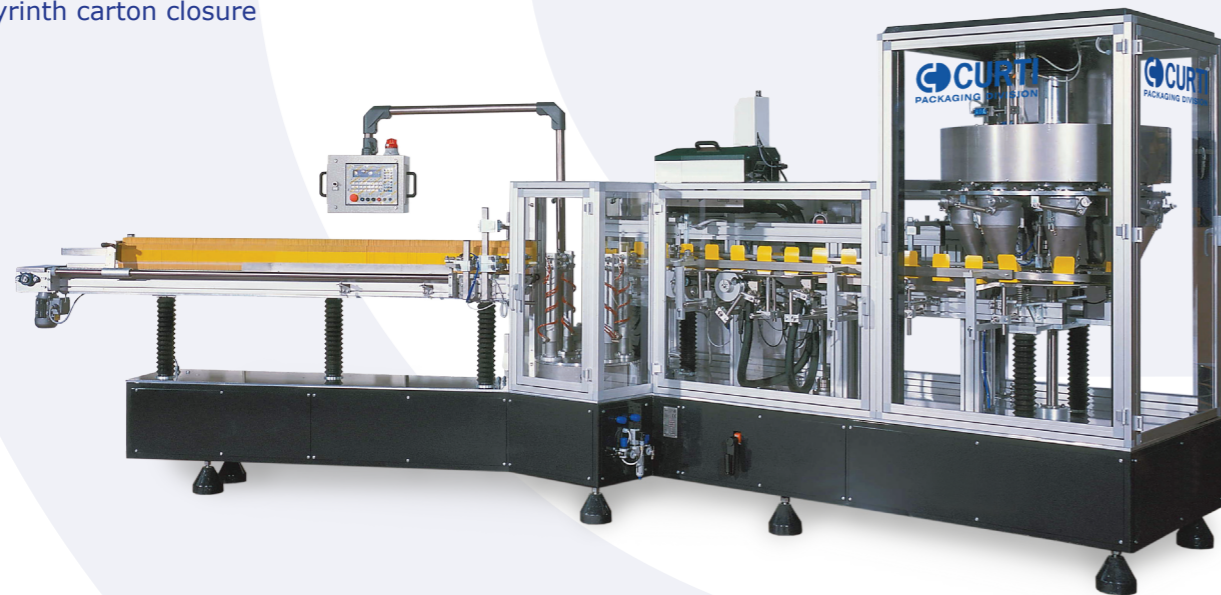

# 1001

SPEED (p.p.m.)    SIZE RANGE (mm)    SPEED HS (p.p.m.)    SIZE RANGE HS (mm)

100

35

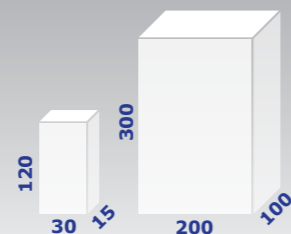

350

100

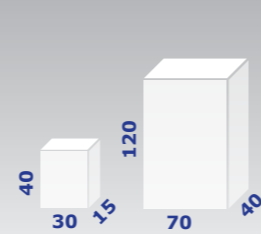

# 1002

**Strong and heavy frame made of steel or stainless steel**  
**Superior hygiene standards and ease of any cleaning operations**

## STANDARD VERSION

- Carton feeding by rotary arms
- Product feeding by volumetric doser, auger filler, multi-head weigher, counting unit
- Flip-top, tuck-in, hot melt glue, even flaps, labyrinth carton closure

## HS

## HIGH SPEED VERSION

- Carton feeding by rotary arms
- N. 10 dosing cups
- Product feeding by volumetric doser, multi-head weigher
- Flip-top, tuck-in, hot melt glue, even flaps, labyrinth carton closure

150

60

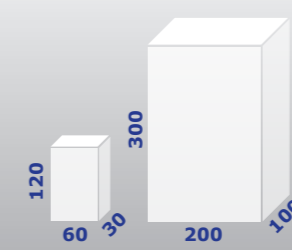

250

100

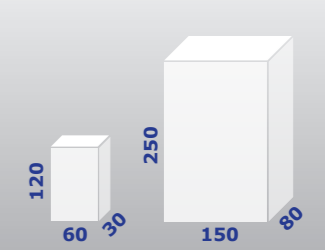

SPEED (p.p.m.)    SIZE RANGE (mm)    SPEED HS (p.p.m.)    SIZE RANGE HS (mm)

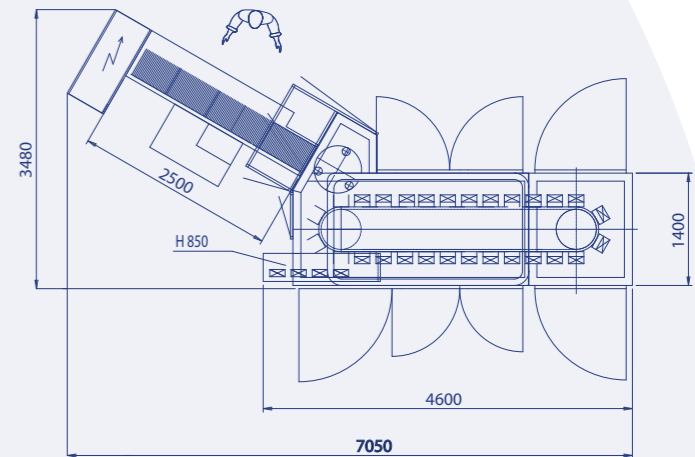

**Overall dimensions (mm):**  
7050 x 3480 x H2300



**Processable products:** powdery products, frozen foods, short pasta, sweets, sugar, salt, dried fruit and vegetables, petfood, seeds, etc...

# 1002