

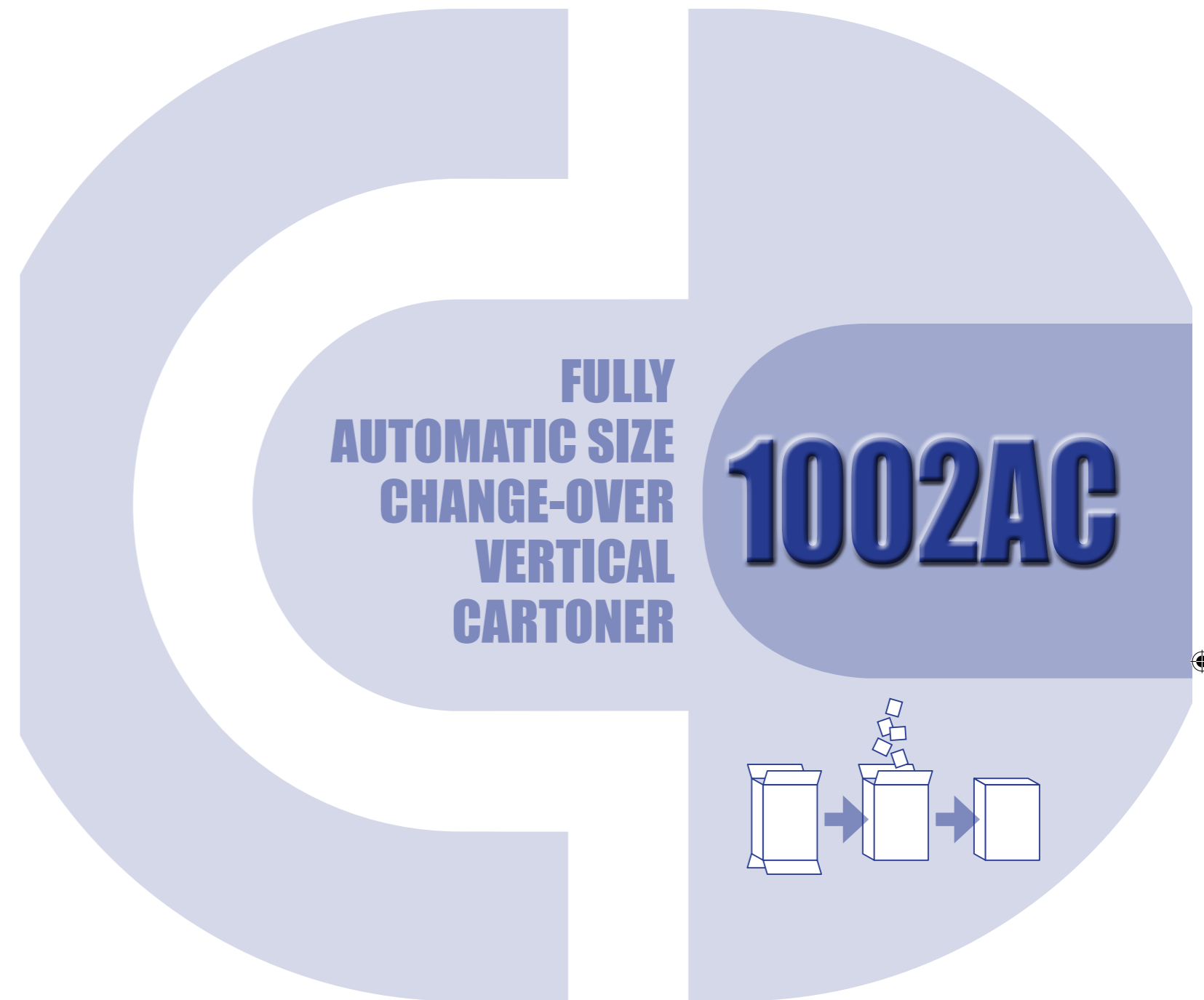

**FULLY AUTOMATIC SIZE CHANGE-OVER
VERTICAL CARTONER**



CURTI Costruzioni Meccaniche S.p.A.
Via Emilia Ponente, 750 - 48014 Castel Bolognese (Ra) - ITALY
Tel. +39 0546 655911 - Fax +39 0546 655904
E-mail: info@curti.com - Web: www.curti.com



1002AC

1002AC

Fully Automatic size change-over Vertical Cartoner

1002 AC vertical cartoner is specifically developed to handle a great variety of products, such as **wrapped or flow-packed** products to meet the Home Care and Food market requirements.

Its **ergonomic design** guarantees a full accessibility to all working stations. The use of electronically controlled axes ensures smooth and precise movements.

The loss of time and production due to size change-over is not a problem anymore. This new cartoner (Patent Pending) allows the **size change-over in one minute** by just pushing a button. All the adjustments are automatically done without replacing any spare parts.

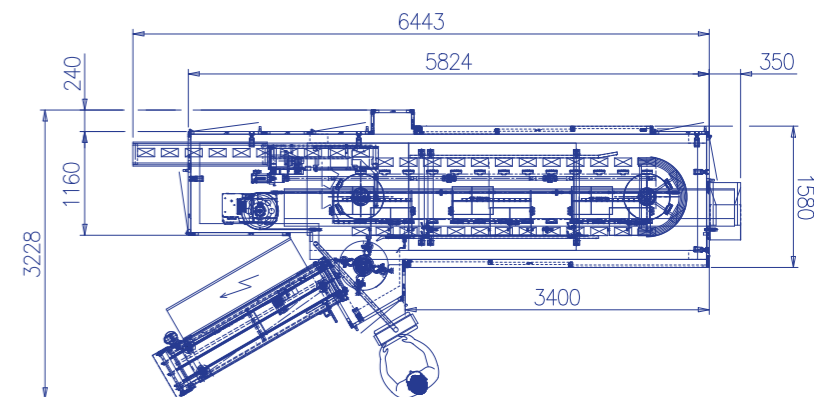
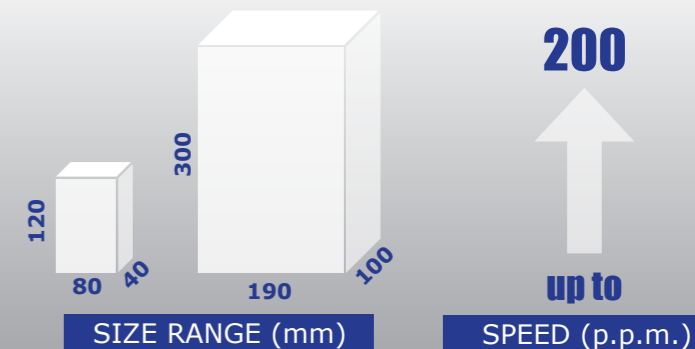

Overall dimensions (mm): 6440 x 3200 x H2300

Main Technical Features

- Continuous motion for high speed production
- One minute for complete size change-over
- High hygiene and easy cleaning
- Product feeding by counting device, scale, multi-head weigher
- Hot melt closure of the carton

fully Automatic size change-over

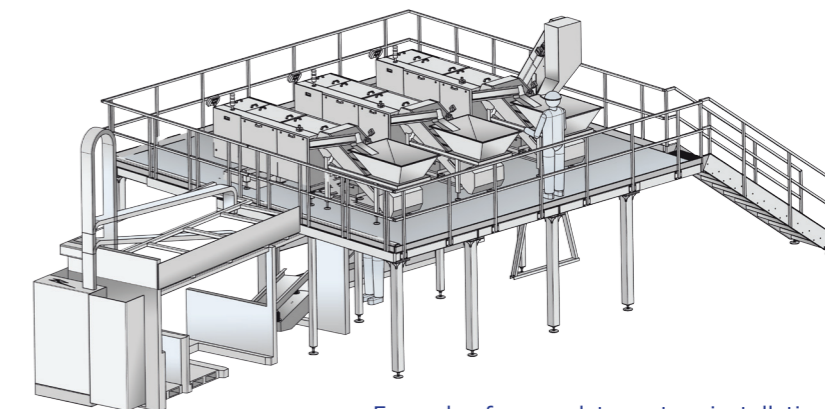
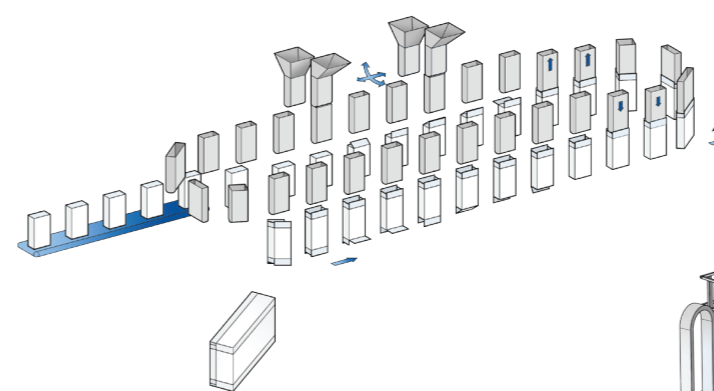
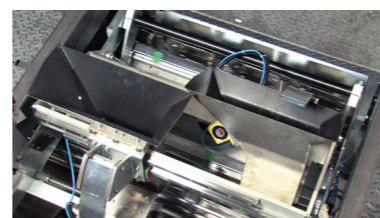
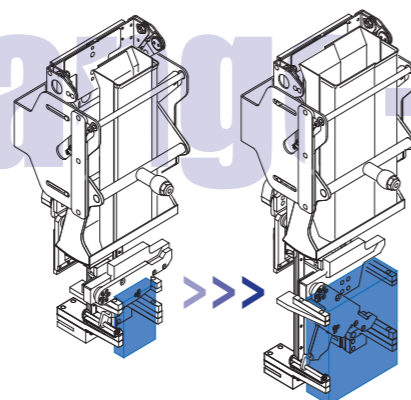

Example of a complete system installation