

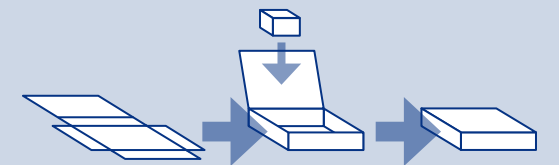

WRAPAROUND FORMING FILLING & CLOSING MACHINE

**WRAPAROUND
FORMING
FILLING & CLOSING
MACHINE**

**C13
SERIES**



CURTI Costruzioni Meccaniche S.p.A.

Via Emilia Ponente, 750 - 48014 Castel Bolognese (Ra) - ITALY
Tel. +39 0546 655911 - Fax +39 0546 655904
E-mail: info@curti.com - Web: www.curti.com



C13 SERIES

C13

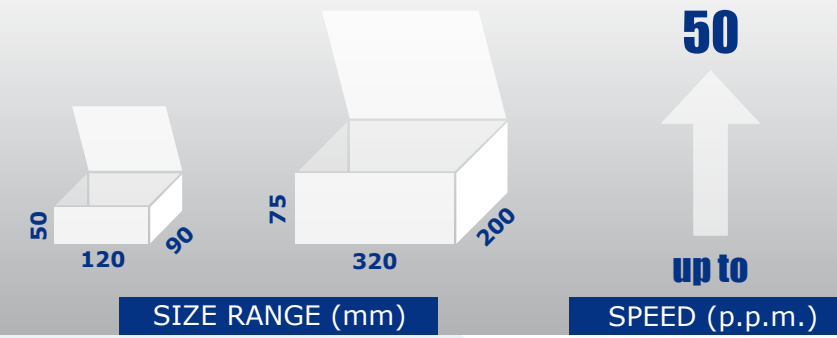

Wraparound Forming, Filling and Closing machine

compact
& versatile

- Extremely compact and versatile
- Precision of all the mechanical movements
- Adaptability to different feeding systems
- Full accessibility to all the working stations
- High flexibility by quick size-changeover

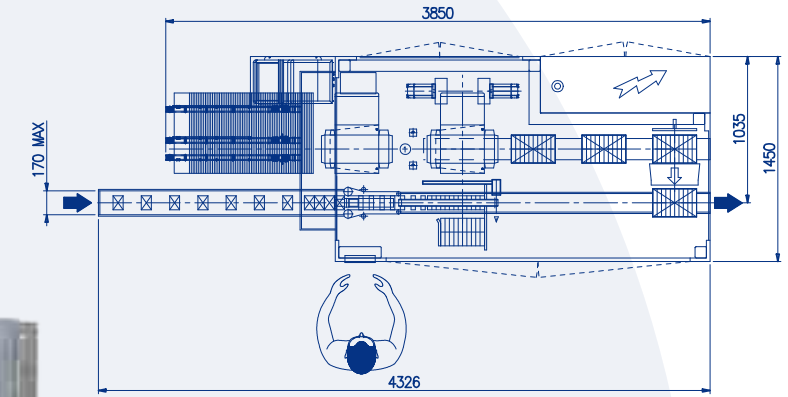

Overall dimensions (mm): 3850 x 1450 x H2050

Main Technical Features

- Modular construction for different machine configurations
- In line or 90° feeding system
- Large capacity of the magazine installed in very ergonomic position
- Positive tray forming around the product
- Product filling by Pick and Place
- Tuck-in or/and hot glue closures
- ELAU motion integrated PLC
- Max mechanical outspeed:
25 cartons/min (by single feeding)
50 cartons/min (by double feeding)
- Complete changeover: 30 minutes

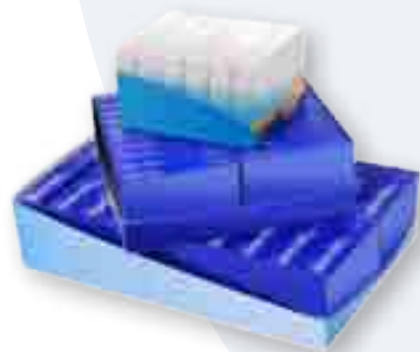

Weight	kg 3800
Air consumption	250 NI/min @ 6 bars
Installed power	21 kW
Absorbed Power	10 kW
Noise level	< 80 dB

