

Top Loading Case Packer C80 Series

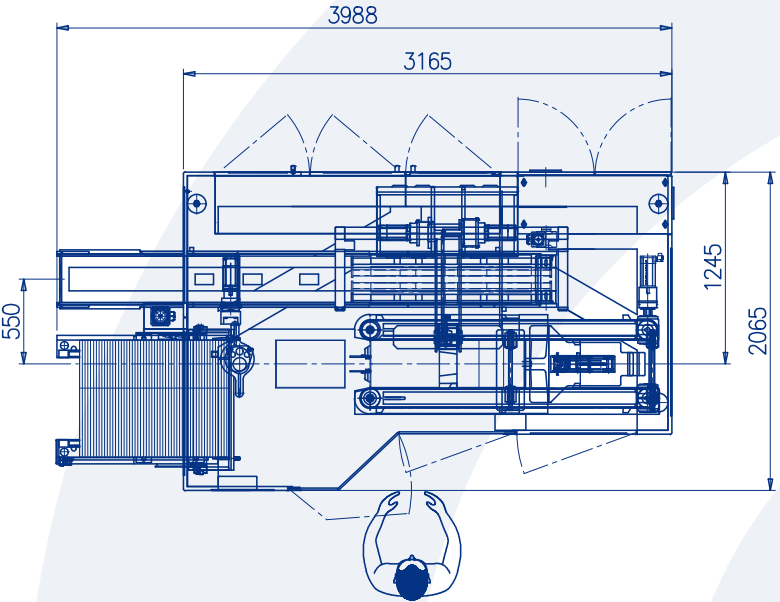

Overall dimensions (mm): 3988 x 2065 x H2397

Box forming



Feeding system



Top loading



Outfeed belt



TOP LOADING CASE PACKER

TOP LOADING CASE PACKER

C80 SERIES

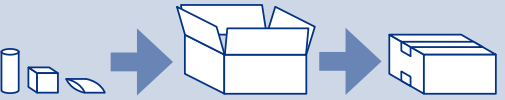

CURTI Costruzioni Meccaniche S.p.A.
 Via Emilia Ponente, 750 - 48014 Castel Bolognese (Ra) - ITALY
 Tel. +39 0546 655911 - Fax +39 0546 655904
 E-mail: info@curti.com - Web: www.curti.com



C80 SERIES

CASE PACKER

Top loading case packer specifically developed to handle a great variety of products such as nude or bundled bottles, tubes, jars, flow-packs, pillow bags and pouches.

Thanks to its great **versatility**, it successfully meets the needs of the Pharmaceutical, Cosmetic and Food industry.

Available in two different versions, **standard and High Speed HS**, can handle both American and tray & lid cases.



C80

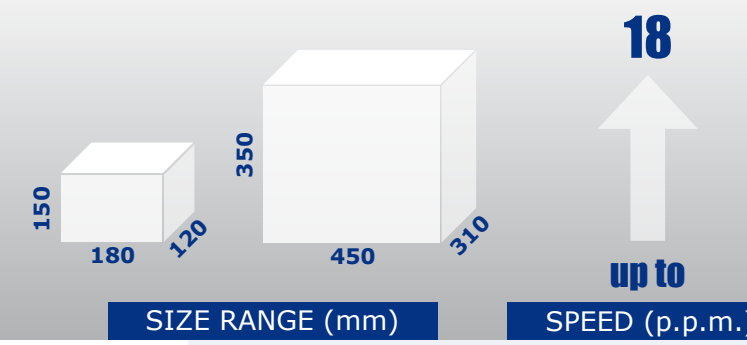

Main Technical Features

- Modular construction enabling different machine configurations, customized to match Customers' needs
- In-line or 90° product feeding system
- Large capacity blanks magazine, placed in ergonomic position for an easy load
- Compact design, engineered to grant a full accessibility to all the working stations
- Modular pick & place system for the case top loading (up to n.3 products gripping head)
- Positive case forming by means of vacuum cups
- Case closure by adhesive tape or hot-melt glue
- Label printing and application can be implemented as optional
- Max. mechanical speed of 18 cycles/min (standard version)
- Max. production speed of 36 boxes/min in case of High Speed HS version
- Complete changeover in 18 min by quick changeover systems developed for all the format parts

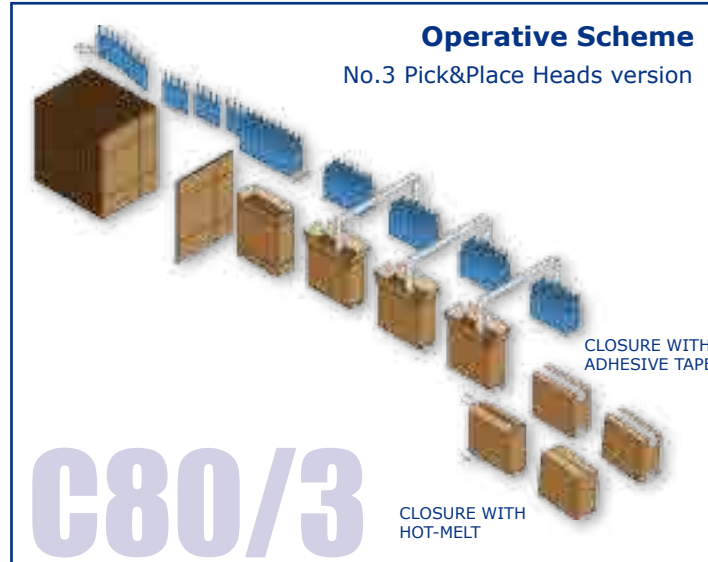
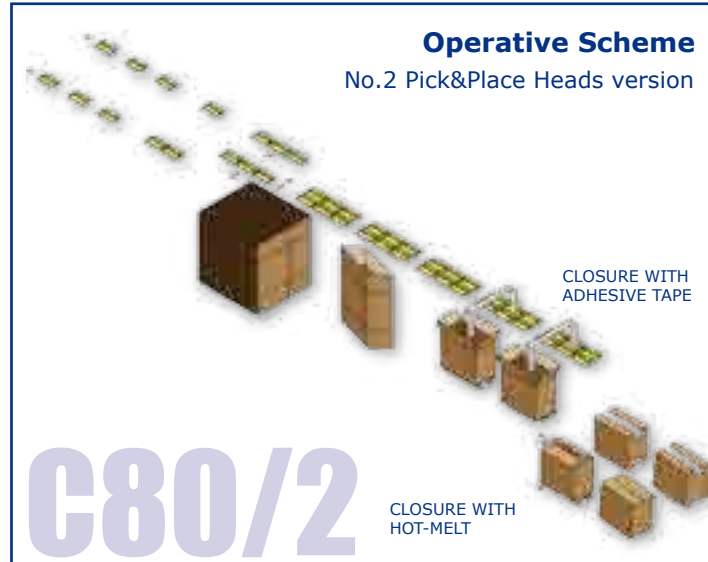
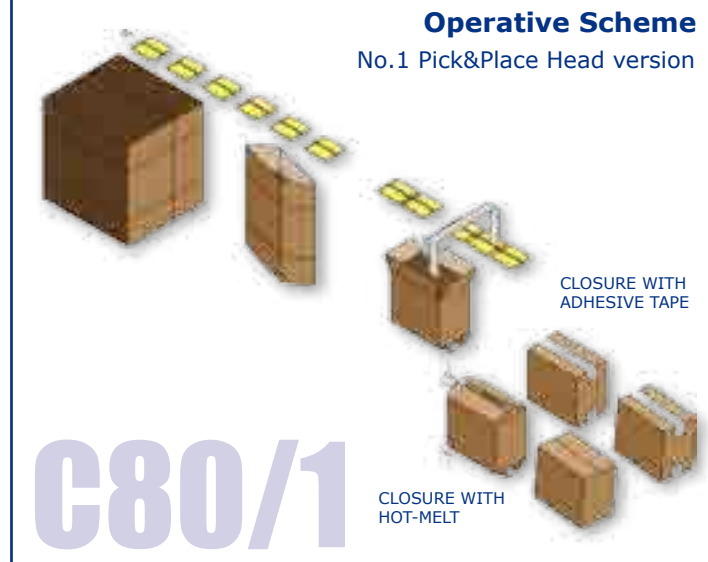

C80-HS

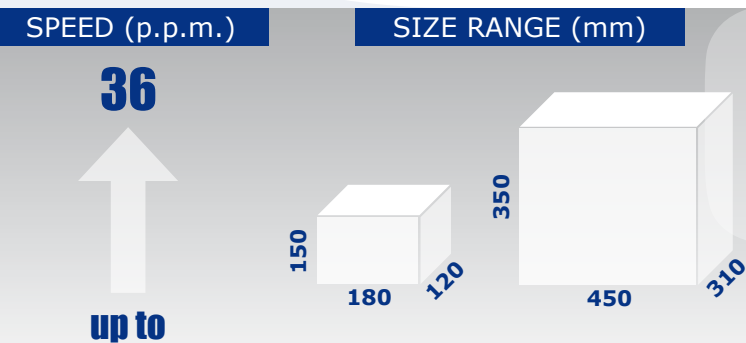

Weight	kg 5100
Air consumption	220 NI/min @ 6 bars
Installed power	24 kW
Absorbed Power	11 kW
Noise level	< 80 dB