

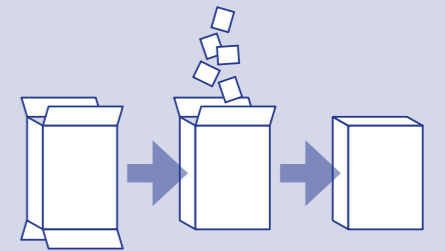

VERTICAL CARTONING MACHINES

**VERTICAL
CARTONING
MACHINES**

**1001
1002**



CURTI Costruzioni Meccaniche S.p.A.
Via Emilia Ponente, 750 - 48014 Castel Bolognese (Ra) - ITALY
Tel. +39 0546 655911 - Fax +39 0546 655904
E-mail: info@curti.com - Web: www.curti.com



1001

Processable products: short pasta, rice, sweets, candies, chewing-gums, twist wrapped chocolates, chocolate powder and flakes, cereals, dried fruit, dried vegetables, petfood, seeds, etc...

STANDARD VERSION

- Main structure in steel and aluminum
- Rotary carton feeding by two arms
- Product feeding by volumetric doser, auger filler, multi-head weigher, counting unit
- Four dosing cups
- Flip-top, tuck-in, hot melt glue, even flaps, labyrinth carton closure

HIGH SPEED VERSION

- Ideal for candies, chocolates, chewing-gums, sweets and any other bulk products
- Carton feeding by rotary arms
- Product feeding by volumetric doser, counting unit, multi-head weigher
- Flip-top, tuck-in, hot melt glue, even flaps, labyrinth carton closure

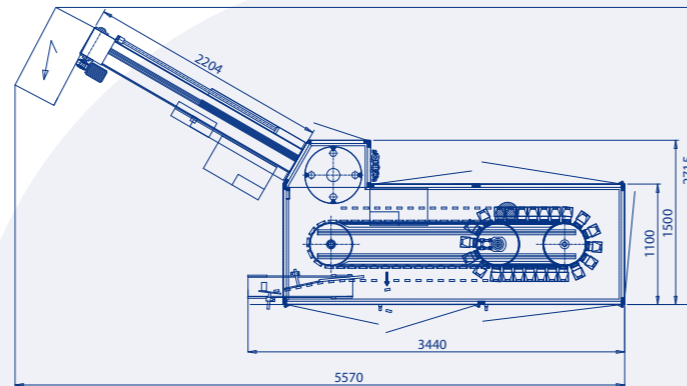

Overall dimensions (mm):
5570 x 2715 x H1880



1001

SPEED (p.p.m.)

SIZE RANGE (mm)

SPEED HS (p.p.m.)

SIZE RANGE HS (mm)

100

35

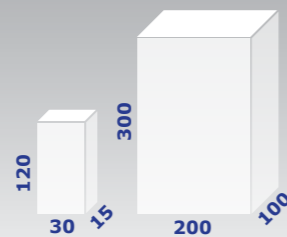

350

100

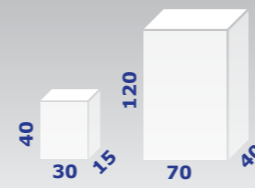

1002

150

60

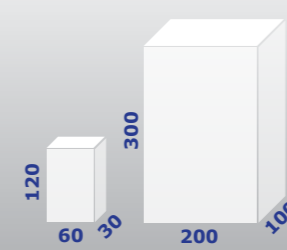

SPEED (p.p.m.)

SIZE RANGE (mm)

250

100

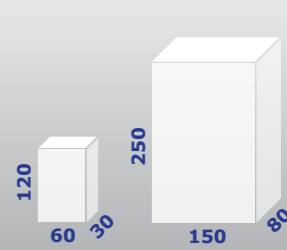

SPEED HS (p.p.m.)

SIZE RANGE HS (mm)

Strong and heavy frame made of steel or stainless steel
Superior hygiene standards and ease of any cleaning operations

STANDARD VERSION

- Carton feeding by rotary arms
- Product feeding by volumetric doser, auger filler, multi-head weigher, counting unit
- Flip-top, tuck-in, hot melt glue, even flaps, labyrinth carton closure

HS

HIGH SPEED VERSION

- Carton feeding by rotary arms
- N. 10 dosing cups
- Product feeding by volumetric doser, multi-head weigher
- Flip-top, tuck-in, hot melt glue, even flaps, labyrinth carton closure

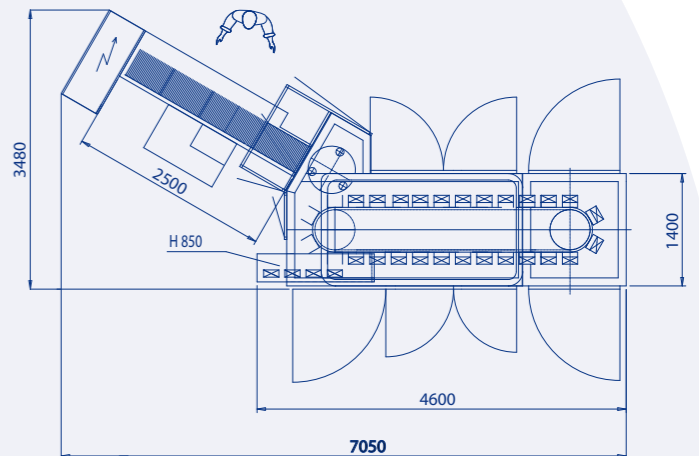

Overall dimensions (mm):
7050 x 3480 x H2300



Processable products: powdery products, frozen foods, short pasta, sweets, sugar, salt, dried fruit and vegetables, petfood, seeds, etc...

1002